

REV.	DESCRIPTION	DATE
A	RELEASE	Jun 01, 2019

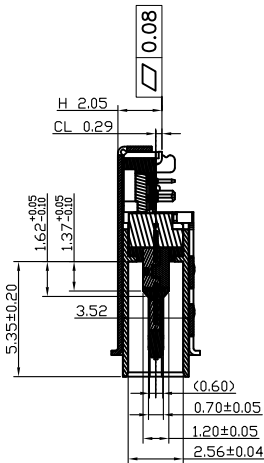

SECTION A-A

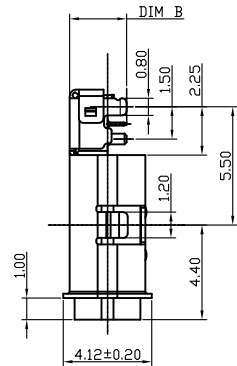
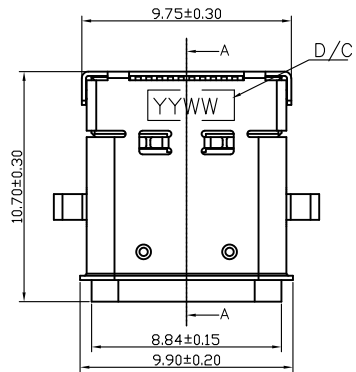
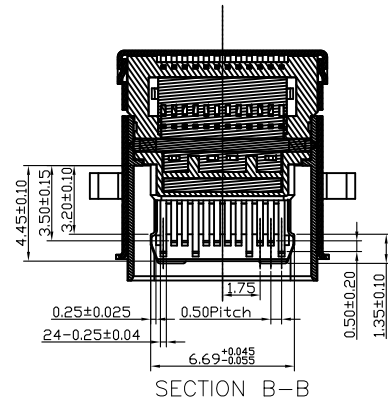
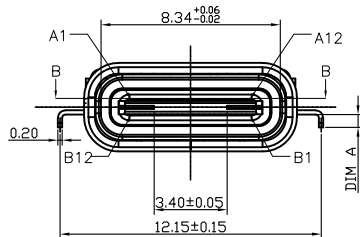

SECTION B-B

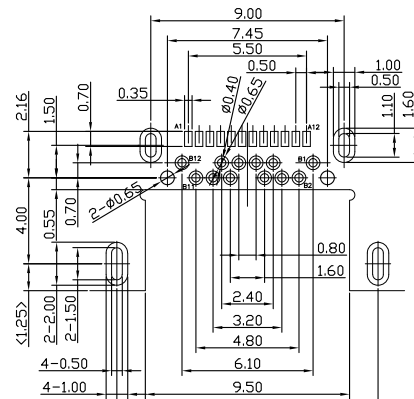
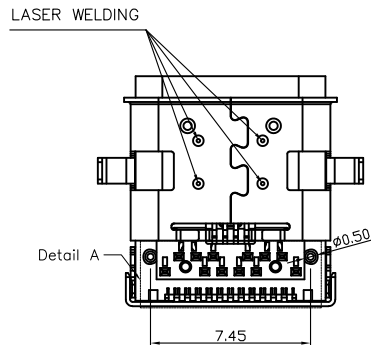
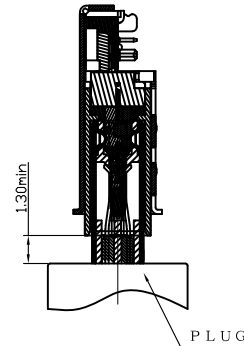

RECOMMEND PCB LAYOUT  
TOLERANCE: ±0.05  
TOP VIEW

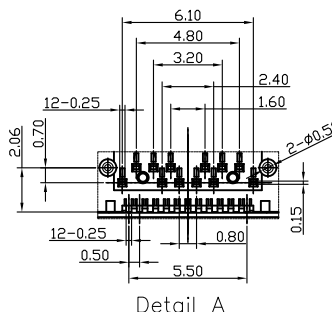

Detail A

**MATERIALS**

1. HOUSING :THERMOPLASTIC (UL 94V-0) .
2. TERMINAL : COPPER ALLOY, PLATING SEE TABLE.
3. SHELL :SUS,NICKEL PLATING OVER ALL.
3. OUT SHELL :SUS,NICKEL PLATING OVER ALL.

**SPECIFICATION**

1. CURRENT RATING : 5A FOR VBUS PIN;  
1.25A FOR VCONN PIN.
2. VOLTAGE RATING: 20 V MAX
3. DIELECTRIC WITHSTANDING VOLTAGE :  
100V AC R.M.S. FOR 1 MINUTE.
4. INSULATION RESISTANCE : 100MΩ MIN.AT 100V DC.
5. CONTACT RESISTANCE : 40mΩ MAX.
6. OPERATING TEMPERATURE : -40°C TO +85°C.
7. DURABILITY: 10000 CYCLES

**PART NUMBER INFORMATION :**

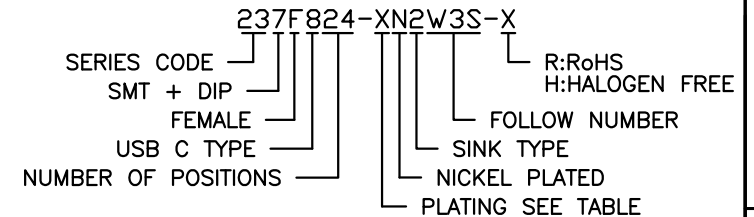

DESCRIPTION OF PLATING ON TERMINALS			
NO.	EXPLAIN	NO.	EXPLAIN
0	GOLD FLASH	3	GOLD 15u"
1	GOLD 5u"	4	GOLD 20u"
2	GOLD 10u"	6	GOLD 30u"

<b>TOLERANCE</b> .0=±0.25 .00=±0.15 .000=±0.05 ANG.=±3°	DRAWER <i>ZL</i> CHECK <i>ZL</i>	<b>INMO</b> 东莞市英墨电子有限公司 INMO Electronics Co.,Ltd	
	APP'D <i>RAWX</i>		NAME USB C TYPE 24PIN 板上 防水
UNITS : mm	PRODUCT SPEC. —	DRAW NO. R237F824-XN2W3S-X	
SCALE NONE	SIZE A4	SHEET 1 OF 3	REV. A

REV.	DESCRIPTION	DATE
A	RELEASE	Jun 01, 2019

增加防水圈示意图

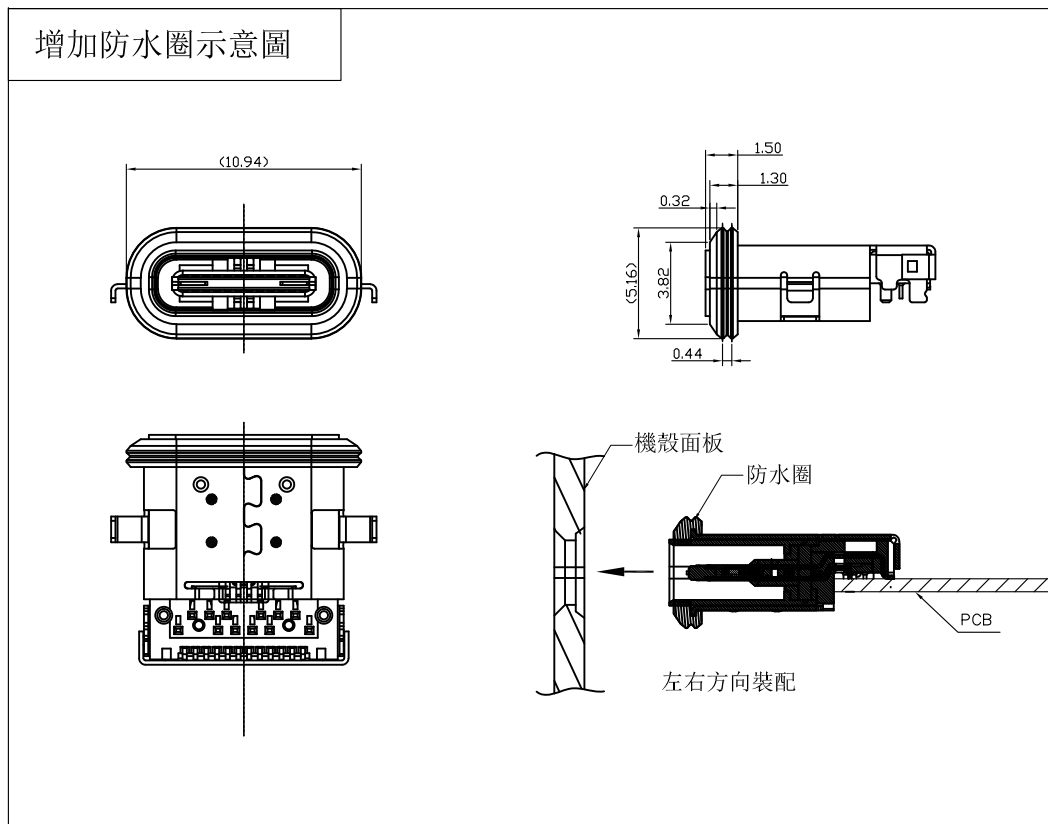

Pin	Signal Name	Mating Sequence	Pin	Signal Name	Mating Sequence
A1	GND	First	B12	GND	First
A2	SSTXp1	Second	B11	SSRXp1	Second
A3	SSTXn1	Second	B10	SSRXn1	Second
A4	V <sub>BUS</sub>	First	B9	V <sub>BUS</sub>	First
A5	CC1	Second	B8	SBU2	Second
A6	Dp1	Second	B7	Dn2	Second
A7	Dn1	Second	B6	Dp2	Second
A8	SBU1	Second	B5	CC2	Second
A9	V <sub>BUS</sub>	First	B4	V <sub>BUS</sub>	First
A10	SSRXn2	Second	B3	SSTXn2	Second
A11	SSRXp2	Second	B2	SSTXp2	Second
A12	GND	First	B1	GND	First
SHELL	GND		SHELL	GND	

<b>TOLERANCE</b>		<b>DRAWER</b>		<b>INMO</b> 东莞市英墨电子有限公司 INMO Electronics Co.,Ltd
.0=±0.25		SL		
.00=±0.15		<b>CHECK</b>		<b>NAME</b> USB C TYPE 24PIN 板上 防水
.000=±0.05		SL		
ANG.=±3°		<b>APP'D</b>		<b>DRAW NO.</b> R237F824-XN113S-X
		SL		
		<b>PRODUCT SPEC.</b>		
<b>UNITS : mm</b>				
<b>SCALE</b>	<b>SIZE</b>	<b>SHEET</b>	<b>REV.</b>	
NONE	A4	2 OF 3	A	

REV.	DESCRIPTION	DATE
A	RELEASE	Jun 01, 2019

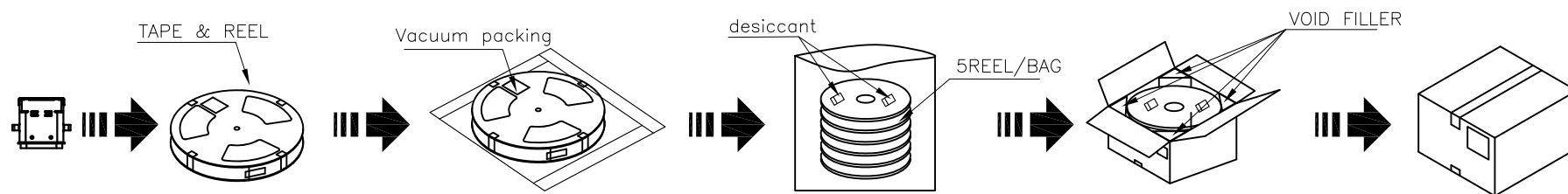
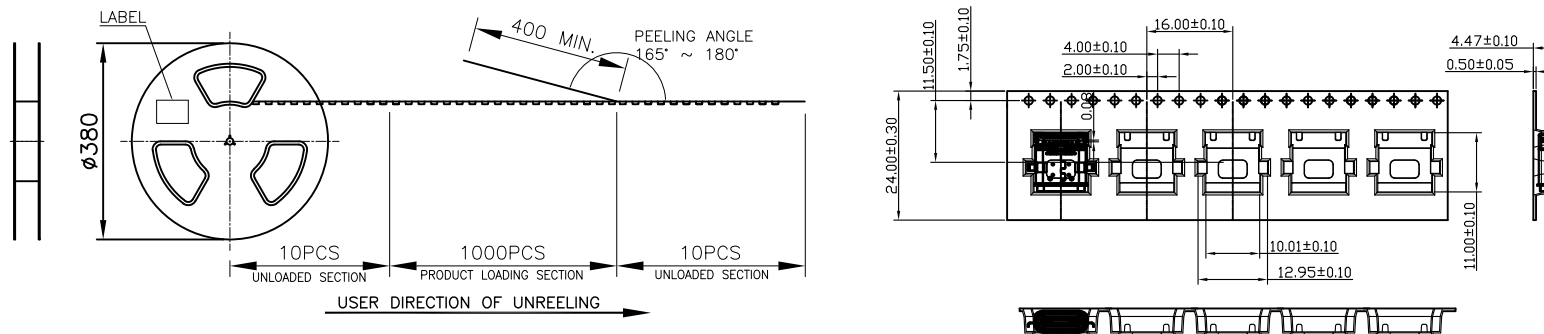

NOTE:  
 1.MATERIAL:  
 BOX: FIBREBOARD, CORRUGATED, DOUBLE WALL.  
 TAPE: POLYSTYRENES, HEAT-RESISTANT TEMPERATURE: 120°C, BLACK COLOR.  
 REEL: POLYSTYRENES, HEAT-RESISTANT TEMPERATURE: 70°C, BLUE COLOR.  
 BAG: POLYETHYLENE, HEAT-RESISTANT TEMPERATURE: 100°C.  
 2.PEELING STRENGTH: 0.1 ~ 1.3 N (10 ~ 130 GRAMS)  
 3.PEELING SPEED: 300 mm/min.  
 4.EACH BAG SHALL BE INCLUDED DESICCANT.

1000	5	5000 PCS	-- KG	-- KG
PCS/REEL	REELS/CARTON	QUANTITY	GROSS WEIGHT	NET WEIGHT

<b>TOLERANCE</b>		<b>DRAWER</b>		<b>INMO</b> 东莞市英墨电子有限公司 INMO Electronics Co.,Ltd	
.0=±0.25		ZL			
.00=±0.15		CHECK		NAME	
.000=±0.05		ZL		USB C TYPE 防水 (包装图)	
ANG.=±3°		APP'D		DRAW NO.	
		KAWK		R237F824-XN113S-X	
		PRODUCT SPEC.			
UNITS : mm		SCALE		SHEET	
		NONE		3 OF 3	
		SIZE		REV.	
		A4		A	